



READ THIS MANUAL CAREFULLY!
It contains important safety information.
Keep it for future reference.

HOLLOWGRAM SL CRANKSETS

Owner's Manual Supplement

122169.PDF

CONTENTS

CRANKARM REMOVAL	2	BEARING INSTALLATION	9
CRANKARM INSTALLATION	4	BB30 ADAPTER	10
SPINDLE INSTALLATION.....	6	HOLLOWGRAM SL ROAD	12
SPINDLE REMOVAL	7	HOLLOWGRAM SL MOUNTAIN	14
BEARING INSPECTION	8	MAINTENANCE	16
BEARING REMOVAL	8		



WARNING

This supplement may include procedures beyond the scope of general mechanical aptitude. Special tools, skills, and knowledge may be required. Improper mechanical work increases the risk of an accident. Any bicycle accident has risk of serious injury, paralysis or death. To minimize risk we strongly recommend that owners always have mechanical work done by an authorized Cannondale retailer.

Please note that the specifications and information in this manual are subject to change for product improvement. For the latest product information, go to <http://www.cannondale.com/tech/>.

Crankarm Removal

1. Insert an Allen key fully into the fixing bolt.

Hollowgram	Hollowgram SL
8mm	10mm

2. Hold crankarm with your hand and turn the Allen key counter-clockwise to remove bolt from the crankarm .



3. Remove the thin steel washer under the bolt head. It is black in color; check the bolt or use a pencil tip to remove it from the crankarm seat.



4. Apply some bicycle bearing grease to the Cannondale tool KT013/.

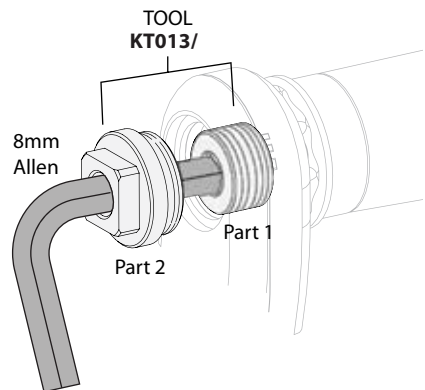

5. Threads tool part 1 into spindle until the top of the stud is flush with the top of the spindle.
6. Install the tool body into the crankarm completely and tighten it snug with a 15mm open end wrench.



6. Install tool part 2 into the crankarm completely and tighten it snug with a 15mm open end wrench.
7. Insert a 8mm Allen key through the tool part 2 and into part 1. Hold the crankarm and turn the Allen key counter-clockwise until the crankarm can be removed from the spindle end.
8. Repeat the previous steps for the other crankarm.



Crankarm Installation

1. Clean the spindle end, spindle threads, crankarm socket and apply a high-quality bicycle bearing grease.



2. Align the splines and install the crankarm onto the spindle end.
3. Apply grease to the bolt threads and thin steel washer.

Install the thin steel washer and fixing bolt into the crankarm and carefully thread into the spindle.



4. Tighten the fixing bolt to 34-41Nm using a torque wrench.
5. Repeat the process above for the other crankarm.



MAKE SURE THE SOCKETS AND SPLINES ARE CLEAN AND APPLY A HIGH-QUALITY BICYCLE BEARING GREASE BEFORE ASSEMBLY.

USE A TORQUE WRENCH TO TIGHTEN.

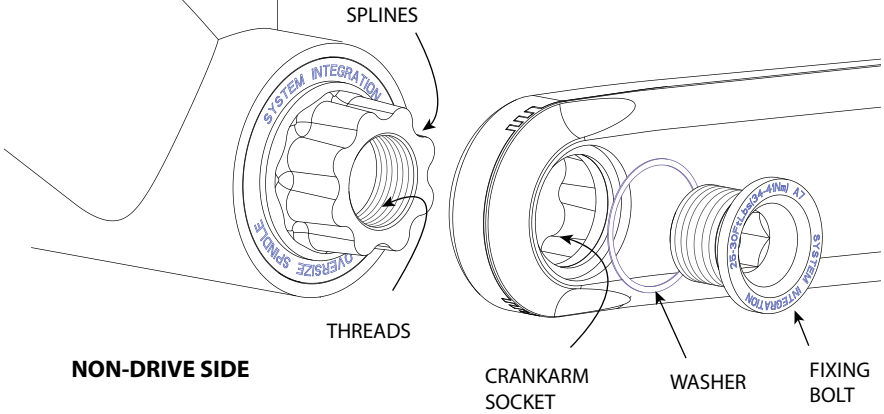

See "Spindle Installation" on page 6 for information on correct number of 0.5mm shims to use and wave washer information.

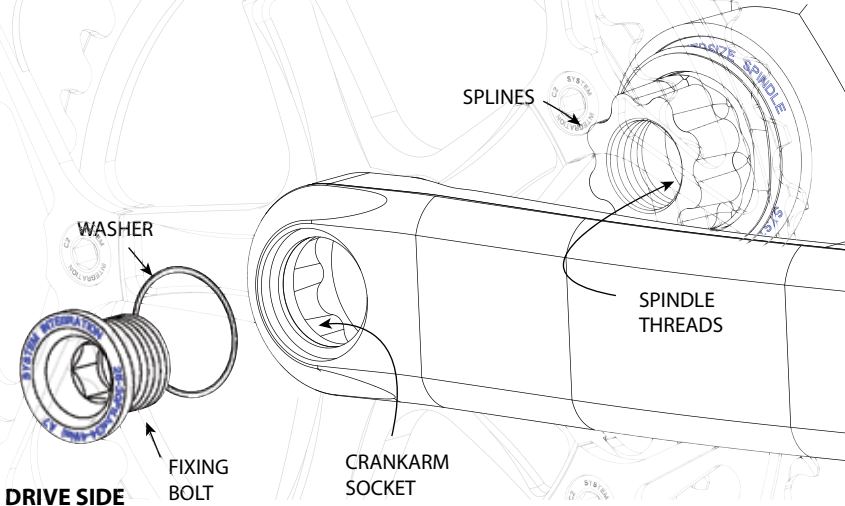

Spindle Installation

1. Slide the left bearing shield (2) onto the spindle (1) with the flat side of the shield facing the ridge (a) on the spindle.
2. Apply a high-quality bicycle bearing grease to all of the outside of the spindle.

* Hollowgram SL Mountain Only

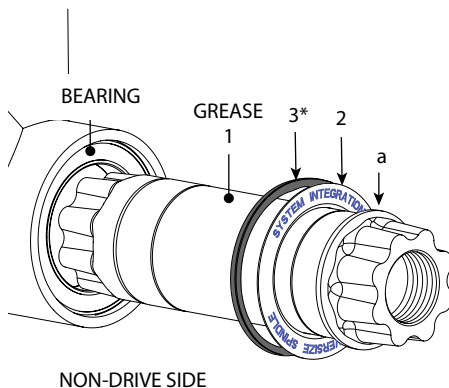

4. On left side of bottom bracket, slide the spindle into the non-drive side of the bottom bracket bearing as shown.



5. Use the mallet drive the spindle into the shell until the shield bottoms against the bearing.

CAUTION

Use only rubber mallet.



6. Install the seal *(1), bearing shield (2), spacers* (3), shims (4) and wave washer (5) onto the drive side spindle end.

NOTE: Up to 5 of the .5mm shims can be used. The total number of shims depends on the compression state of the wave washer with the crankarm installed and tightened to the recommended torque. The wave washer should appear “compressed but not flattened.”

* Hollowgram SL Mountain Only

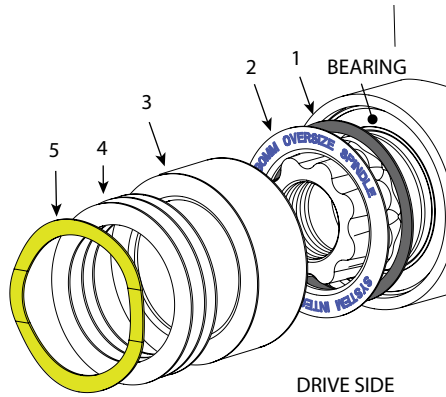

Spindle Removal

1. Remove the drive side crankarm.
2. Remove the small parts from the drive side spindle end (wave washer, shims, spacer (mountain only) bearing shield and seal (mountain only).
3. On the drive side, tap the spindle end to drive it out the non-drive side. Pull it out on the non-drive side with your hand.

NOTE: Use a dowel (PVC shown) on the spindle end once it is inside the shell to continue driving the spindle out.



CAUTION

Use only rubber mallet.



Bearing Inspection

1. Remove the crankarms and spindle from the bottom bracket shell.
2. Rotate the inner bearing race of both bearings; rotation should be smooth and quiet. No bearing play or movement inside the shell. If the bearing is damaged, replace both bearings with new ones.



Bearing Removal

Frequent or routine renewal of undamaged bearings is not recommended. Repeated removal and reinstallation can damage the inside BB shell surfaces resulting in poor bearing fit.

1. To remove the bearings, position Cannondale tool KT011/ behind the bearing so that the tool ridges are seated on the bearing.
2. Insert a driver (punch or drift) from the opposite side. Locate it on the back of the tool and use light tapping to drive the bearing from the shell.

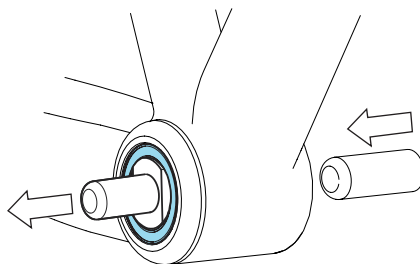
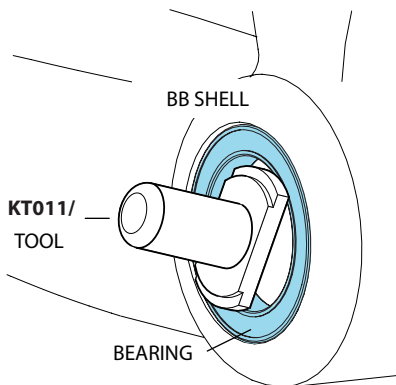

Bearing Installation

1. Clean the inside and outside surfaces of the bottom bracket shell.
2. Apply a high-quality bicycle bearing grease to the inside surface of the shell.
3. Install the square end of the circlip into the groove first, then moving clockwise, push the clip into the groove until it is fully seated in the groove. Install the other circlip the same way.
4. With a headset press, and tool KT010/ install the bearings into the shell as shown. Press the bearing until it is seated against the circlip.
5. To finish, apply a light coating of a high-quality bicycle bearing grease to both sides of each bearing to help repel moisture.

NOTE: Circlip removal is unnecessary for bearing replacement unless the circlip is damaged. damage is present. A damaged circlip can be removed by using a small thin-blade screw driver to lift the hooked end up out of the groove and then pushing the circlip out counter-clockwise.

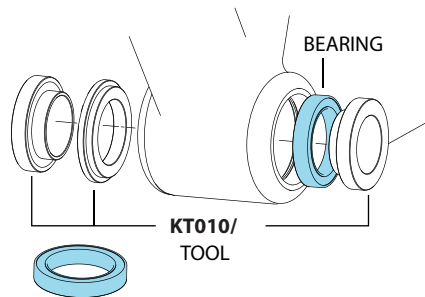
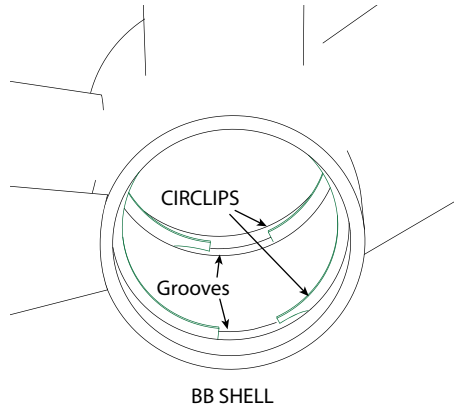

WARNING

SHARP EDGES. Circlips can have sharp edges. Wear hand protection.

CAUTION

Do not face, mill or machine the BB30 bottom bracket shell.

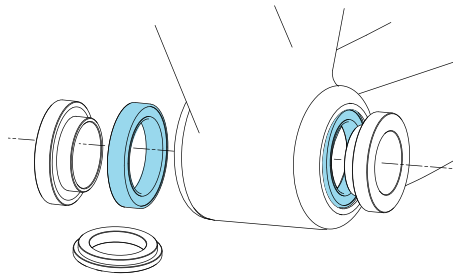

BB30-to-Standard English Thread Adapter

The SI bottom bracket adapter enables the use of standard English/68mm or 73mm bottom bracket cranksets in Cannondale System Integration (SI) road or mountain bicycle frames.

WARNING

SERIOUS FRAME DAMAGE

On bicycle frames with carbon fiber BB shells, once installed the adapter is a non-removable/permanent frame part. Do not remove it. Adapters must be installed by a professional bike mechanic.

NOTE: The adapter IS NOT a frame repair part and will only work in undamaged frames in good condition. Improper installation or removal can result in damage and void applicable frame warranty.

Installation

1. Remove bearings and circlips from BB shell.
2. Clean inside of the bottom bracket shell. Remove all grease. Do not use abrasives.
3. Apply Loctite 609 to the BB shell bearing seat surfaces ensuring complete coverage and install the ADAPTER with the groove on the drive side using a headset bearing press and the installation tool. Press the ADAPTER until the groove side face is flush with the drive side face of the SI BB shell.
4. Allow at least 12 hours (at 72°F) for the Loctite to cure before installing the standard bottom bracket crankset. Follow manufacturer's instructions. Loctite Technical Data Sheet <http://tds.loctite.com/tds5/docs/609-EN.PDF>

Removal

The adapter is removable only on alloy BB frames, however, repeated removal and reinstallation could result in damage to the SI BB shell and is not recommended.

1. Removal with extraction tool KF366/ , a two-piece tool set used with a headset bearing press. The arrangement of the tool parts for removal is shown next figure.
2. Following removal, clean all remaining Loctite residue with a before reinstalling the SI circlips and bearings. Use Loctite 768. Use a dental pick to remove any adhesive from the grooves. Do not cut, face, or use abrasives to clean the inside if the BB shell.

INSTALLATION

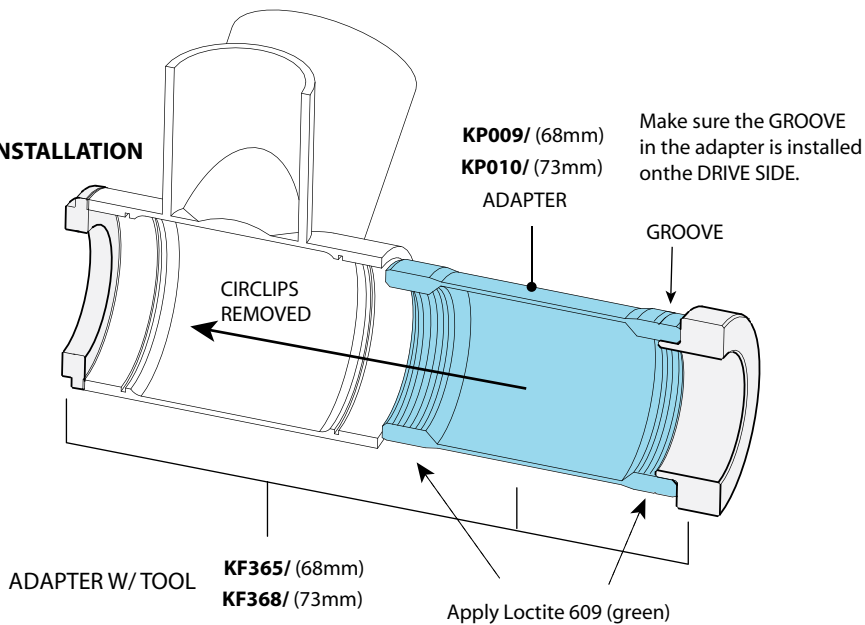

REMOVAL

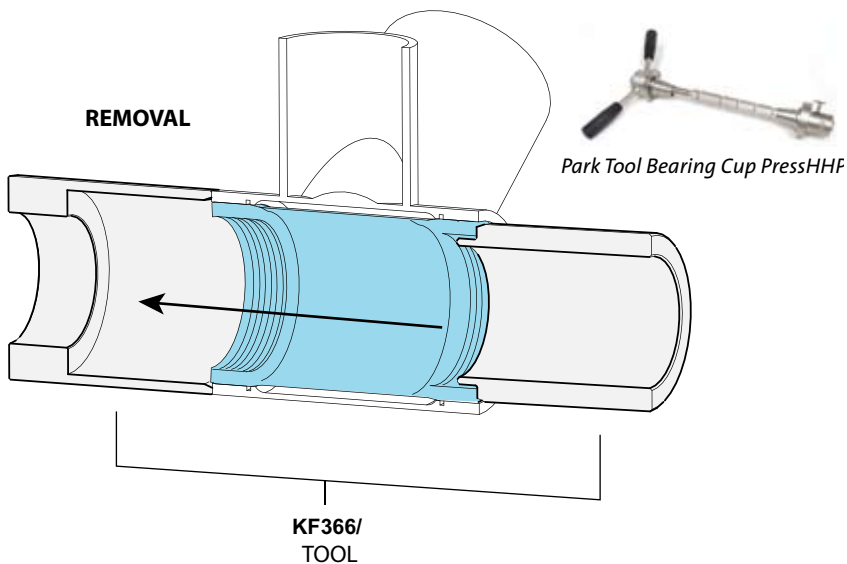

HOLLOWGRAM SL ROAD

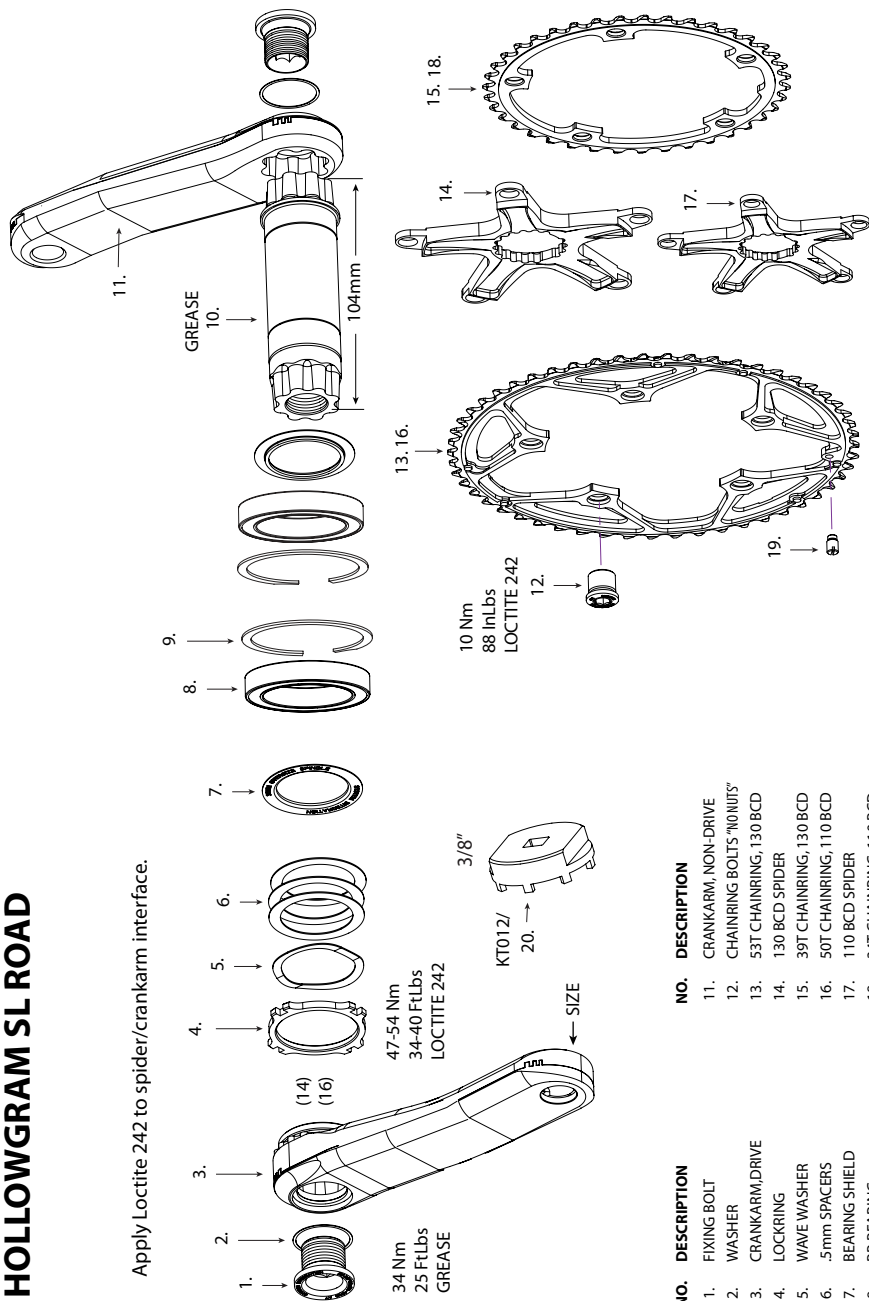

NO.	DESCRIPTION	NO.	DESCRIPTION
1.	FIXING BOLT	11.	CRANKARM, NON-DRIVE
2.	WASHER	12.	CHAINRING BOLTS "10 INUIS"
3.	CRANKARM, DRIVE	13.	53T CHAINRING, 130 BCD
4.	LOCKRING	14.	130 BCD SPIDER
5.	WAVE WASHER	15.	39T CHAINRING, 130 BCD
6.	.5mm SPACERS	16.	50T CHAINRING, 110 BCD
7.	BEARING SHIELD	17.	110 BCD SPIDER
8.	BB BEARING	18.	34T CHAINRING, 110 BCD
9.	BB CIRCLIP	19.	CATCH PIN
10.	SPINDLE	20.	LOCKRING TOOL

SRM Powercontrol Spindle & Shield

To maintain chainstay clearance, SRM units may require use of a special spindle and bearing shield. Note that the ridge on the non-drive side of the spindle is reduced to .85mm and a machined groove is present in the bearing shield.

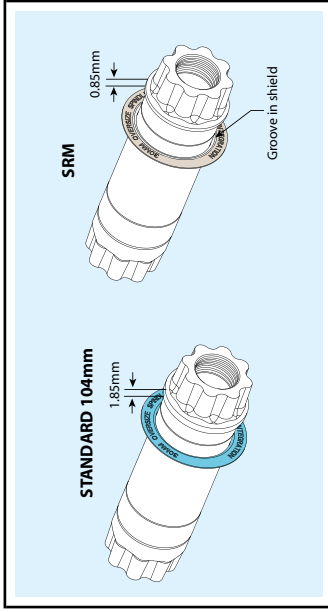

NOTE: Using a standard SI spindle and shield may result in interference of the SRM spider housing and the chainstays. To obtain the special spindle and bearing shield, order Cannondale kit QC850/.

NO.	ORDER NO.	DESCRIPTION
1,2,3,4,11,12,13,14,15,19	KA014/170SLV	KIT,CRANKSET,SL,ROAD 39/53,170
1,2,3,4,11,12,13,14,15,19	KA014/172SLV	KIT,CRANKSET,SL,ROAD 39/53,172
1,2,3,4,11,12,13,14,15,19	KA014/175SLV	KIT,CRANKSET,SL,ROAD 39/53,175
1,2,3,4,11,12,16,17,18,19	KA015/170SLV	KIT,CRANKSET,SL,ROAD 34/50,170
1,2,3,4,11,12,16,17,18,19	KA015/172SLV	KIT,CRANKSET,SL,ROAD 34/50,172
1,2,3,4,11,12,16,17,18,19	KA015/175SLV	KIT,CRANKSET,SL,ROAD 34/50,175
14	QC694/	Kit,Spider,H-GRAM,SI,130MM,BCD
17	QC693/	Kit,Spider,H-GRAM,SI,110mm,BCD
12	KF360/	KIT,BOLT,SI C-RING, MK4/5 ONLY
19	QC603/	Kit,Pin,Chain Catch-SI
13	KP024/	KIT,CHAINRING,MK5-53T/130BCD
15,12	KP025/	KIT,CHAINRING,MK5-39T/130BCD
16	KP026/	KIT,CHAINRING,MK5-50T/110BCD
18,12	KP027/	KIT,CHAINRING,MK5-34T/110BCD
4	KP021/	KIT,LOCKRING-SL --REQUIRES KT012/
11	KP020/170L	KIT,CRANKARM-SL BLK, 170 LFT
11	KP020/172L	KIT,CRANKARM-SL BLK, 172 LFT
11	KP020/175L	KIT,CRANKARM-SL BLK, 175 LFT
3	KP020/170R	KIT,CRANKARM-SL BLK, 170 RHT
3	KP020/172R	KIT,CRANKARM-SL BLK, 172 RHT
3	KP020/175R	KIT,CRANKARM-SL BLK, 175 RHT
5,6,7,8,9,10	QC690/	KIT,BB,CDALE 5i,68X104mm Rd
5,6,7,8,9,10	QC850/	KIT,BB,CDALE 5i,68X104mm Rd-SRM
5,6,7,8,9,10	KA019/	KIT,BB,CDALE 5i,68X104 CERAMIC
9	QC616/	Kit, Cir clip, BB-SI
8	KB6180/	Kit, Bearings-BB-SI; contains 2 bearings for the bottom bracket SKF#6806-2RS /SR12 /90% fill
8	KP018/	KIT, BEARING, BB-SI, CERAMIC, 2PCS
7	KP023/	KIT, BEARING, SHIELD, BB-SL
10	QC612/	Kit, Spindle-SI Road
6	QC617/	Kit, Shims-Plastic, BB-SI; contains 5 shims
5	QC618/	Kit, Washer-wave, BB-SI
1,2	KP022/	KIT, CRANK BOLTS, H-GRAM, SL,(2)

HOLLOWGRAM SL MOUNTAIN

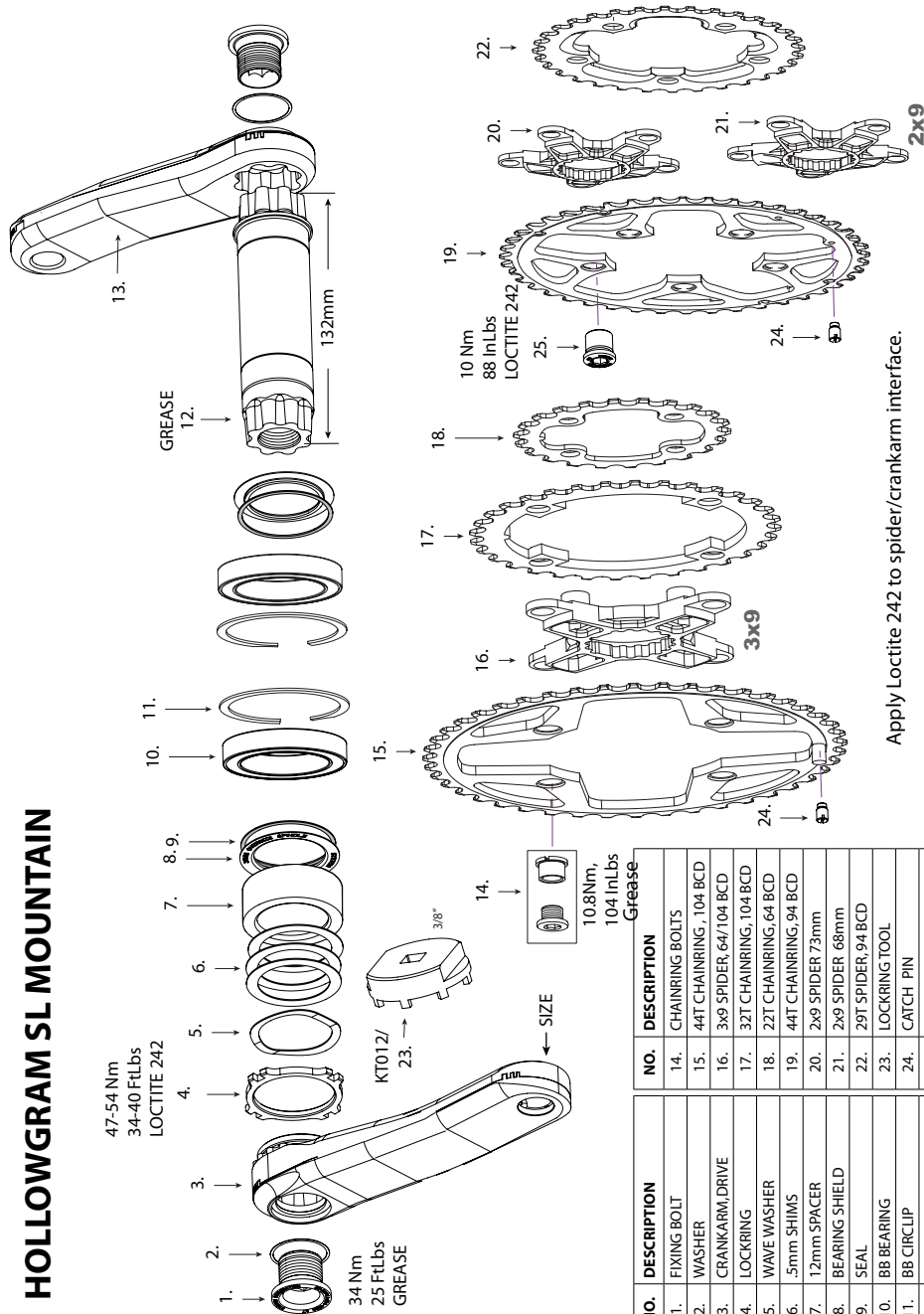

47-54 Nm
34-40 FtLbs
LOCTITE 242

34 Nm
25 FtLbs
GREASE

KT012/
23. →
3/8"

← SIZE
10.8Nm,
104 InLbs
Grease

Apply Loctite 242 to spider/crankarm interface.

NO.	DESCRIPTION	NO.	DESCRIPTION
1.	FIXING BOLT	14.	CHAINRING BOLTS
2.	WASHER	15.	4xT CHAINRING, 104 BCD
3.	CRANKARM, DRIVE	16.	3x9 SPIDER, 64/104 BCD
4.	LOCKRING	17.	32T CHAINRING, 104 BCD
5.	WAVE WASHER	18.	22T CHAINRING, 64 BCD
6.	.5mm SHIMS	19.	44T CHAINRING, 94 BCD
7.	12mm SPACER	20.	2x9 SPIDER 73mm
8.	BEARING SHIELD	21.	2x9 SPIDER 68mm
9.	SEAL	22.	29T SPIDER, 94 BCD
10.	BB BEARING	23.	LOCKRING TOOL
11.	BB CIRCLIP	24.	CATCH PIN
12.	SPINDLE	25.	CHAINRING BOLT "NO NUTS"
13.	CRANKARM, NON-DRIVE		

BEARING SHIELD PLACEMENT

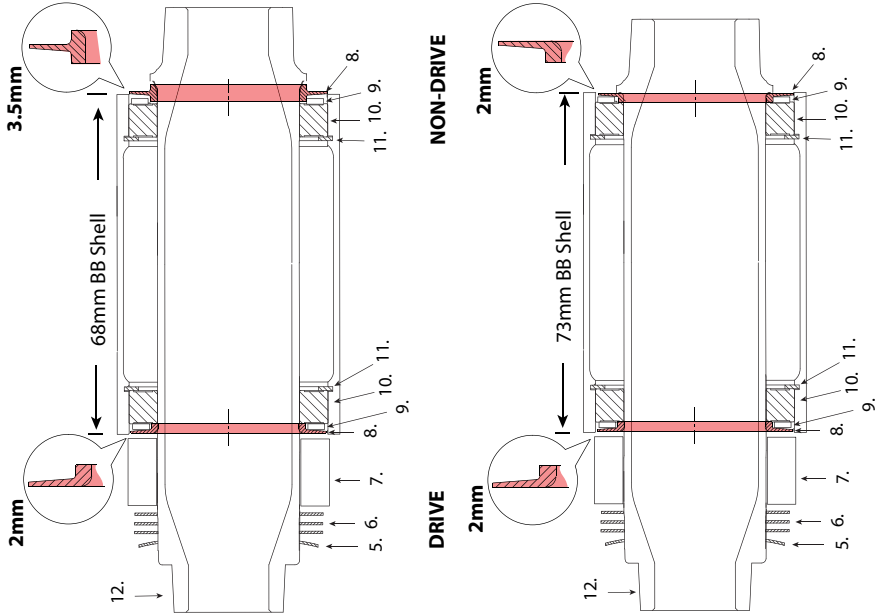

NO.	ORDER NO.	DESCRIPTION
1.2,3,4,13,19,20,22,24,25	KA016/170BLK	KIT,CRANKSET,SL,MTN,2X9,170,73mm Shell
1.2,3,4,13,19,20,22,24,25	KA016/175BLK	KIT,CRANKSET,SL,MTN,2X9,175,73mm Shell
1.2,3,4,13,19,21,22,24,25	KA017/170BLK	KIT,CRANKSET,SL,MTN,2X9,170,68mm Shell
1.2,3,4,13,19,21,22,24,25	KA017/175BLK	KIT,CRANKSET,SL,MTN,2X9,175,68mm Shell
1.2,3,4,13,14,15,16,17,18,24	KA018/170BLK	KIT,CRANKSET,SL,MTN,3X9,170,68 or 73mm Shell
1.2,3,4,13,14,15,16,17,18,24	KA018/175BLK	KIT,CRANKSET,SL,MTN,3X9,175,68 or 73mm Shell
16	KF355/	Kit, SPIDER-SI MTN,64/104BCD/48/ALL USE W/ QC604/
14	QC604/	Kit,Bolts/Nuts Ch,Rings-SI (5)
21	KP030/	KIT,SPIDER-SI MTN,94BCD/58/68 USE W/ KF360/
20	KP031/	KIT,SPIDER-SI MTN,94BCD/58/73 USE W/ KF360/
19	KF360/	KIT,BOLTS I C-RING, MK4/5 ONLY
25	KP028/	KIT,CHAINRING,2X9,44T/94BCD
22,25	KP029/	KIT,CHAINRING,2X9,29T/94BCD
4	KP021/	KIT,LOCKRING-SL --REQUIRES KT012/
13	KP020/170L	KIT,CRANKARM-SL BLK,170 LFT
13	KP020/172L	KIT,CRANKARM-SL BLK,172 LFT
13	KP020/175L	KIT,CRANKARM-SL BLK,175 LFT
3	KP020/170R	KIT,CRANKARM-SL BLK,170 RHT
3	KP020/172R	KIT,CRANKARM-SL BLK,172 RHT
3	KP020/175R	KIT,CRANKARM-SL BLK,175 RHT
5,6,7,8,9,10,11,12	QC851/	KIT,BB,CDALE SI,68/73x132mm
5,6,7,8,9,10,11,12	QC021/	KIT,BB,CDALE SI, 68/73X132 CERAMIC
11	QC616/	Kit, Circlip,BB-SI
10	KB6180/	Kit, Bearings-BB-SI; contains 2 bearings for the bottom bracket SKF#6806-2RS /5R12 /90% fill
10	KP018/	KIT,BEARING,BB-SI,CERAMIC,2PCS
8	KP023/	KIT,BEARING SHIELD,BB-SL
12	QC070/	Kit, Spindle-SI Mtn,68/73 x131mm
6	QC617/	Kit, Shims-Plastic, BB-SI; contains 5 shims
5	QC618/	Kit, Washer-wave, BB-SI
1,2	KP022/	KIT,CRANK BOLTS,H-GRAM SL,(2)
23	KT012/	LOCKRING TOOL
24	QC603/	CHAIN CATCH PIN

Maintenance Schedule

WHAT TO DO	HOW OFTEN
<p>CHECK FOR DAMAGE. Inspect the chainrings, spider, crankarms for any cracks, deep scratches, delamination, gouges before each ride. If any damage is present, do not ride until the damaged components have been replaced with new ones.</p>	<p>BEFORE EVERY RIDE OR AFTER ANY CRASH, FALL, OR IMPACT</p>
<p>CHECK TIGHTENING TORQUES Check the tightening torques of the crankset after initial ride. Consult exploded views for tighten torque values and use a good torque wrench.</p>	<p>AFTER INITIAL RIDE CHECK EVERY 4-5 RIDES</p>
<p>INSPECT BEARINGS Replace damaged bearings with a new set.</p>	<p>ANNUALLY OR ANYTIME CRANKSET IS REMOVED</p>
<p>INSPECT BOTTOM BRACKET SHELL Clean and inspect the frame BB shell for cracks or damage. Do not ride if damage is found. Contact a Cannondale Dealer.</p>	<p>ANNUALLY OR ANYTIME CRANKSET IS REMOVED</p>
<p>INSPECT CRANKSET COMPONENTS Clean and inspect each part of the crankset for damage. Replace any damaged part with a new one before riding.</p>	<p>ANNUALLY OR ANYTIME CRANKSET IS REMOVED</p>



ANY PART OF A POORLY MAINTAINED BIKE CAN BREAK OR MALFUNCTION LEADING TO AN ACCIDENT WHERE YOU CAN BE KILLED, SEVERELY INJURED OR PARALYZED.

Please ask your Cannondale Dealer to help you develop a complete maintenance program, a program which includes a list of the parts on your bike for YOU to check regularly. Frequent checks are necessary to identify the problems that can lead to an accident.